

Experiences with Regenerative Air Heater Performance Evaluations & Optimization

Stephen K. Storm
Storm Technologies, Inc.
P.O. Box 429 (Mail)
411 North Depot Street (Deliveries)
Albemarle, NC 28002
Office: (704) 983-2040
stephen.storm@stormeng.com

John Guffre
Chief Research Scientist
Paragon Airheater Technologies (USA)
23143 Temescal Canyon Rd., Suite B
Corona, CA 92883
Telephone: 888-488-3100
jguffre@paragonairheater.com

In most generating units, the regenerative air heater on a large utility boiler often accounts for over 10% of the unit's thermal efficiency. Its performance is so critical that just a 5.5°C (9.9°F) change in gas exit temperature can change the boiler efficiency by ¼%. Since the air heater is a critical component of the combustion system, evaluating and optimizing an air heater's performance must be done with the requirements of the combustion system in mind. This process includes an integrated evaluation of fuel variations, operating conditions, combustion systems, mill performance, air/gas ratios, related auxiliary equipment, excess oxygen measurement equipment and techniques. Air heater leakage has the largest single effect on air heater performance which, in turn, affects boiler output and efficiency. Leakage can negatively impact mill performance by limiting the amount of available hot primary air. Other issues associated with air heater performance include corrosion, fouling, ammonium bisulfate plugging, increased auxiliary power consumption and higher differentials that lead to fan limitations.

With an aging fleet of boilers operating with ultra low NO_x firing equipment, accurate measurement and control of excess oxygen is critical. On balanced draft boilers, additional air in-leakage upstream of the air heater from leaky penthouses, casings, and expansion joints results in non-optimum measuring conditions for accurately controlling excess oxygen. It is not uncommon for the authors to evaluate and/or identify large deviations from boiler design attributable to these leakage issues. Both air heater leakage and upstream air in-leakage degrade air pollution control equipment performance by increasing the velocity of suspended fly ash and reducing electrostatic precipitator residence time. Taking all of this into consideration, this technical paper will review a comprehensive approach for optimization of air heater and unit performance by integration of a diagnostic testing evaluation in conjunction with proven and recent advances with high performance air heater components.

This paper will focus on (3) areas:

1. Evaluating Air Heater Leakage
2. Evaluating the Impact of the APH on the Combustion Process and Overall Unit Efficiency
3. Air Heater Performance Optimization / Design Provisions

Evaluating Air Heater Performance

Air heater leakage can occur from several different paths in a regenerative air heater. The most common way to measure air heater leakage is by oxygen rise from the flue gas as it enters the air heater (or exits a boiler) with the oxygen content of the flue gas as it leaves the air heater. The O₂ concentrations often measured are typically used to calculate the amount of air leaking past the air heaters' radial seals into the exiting gas stream. These measurements often do not account or provide provisions for air or gas bypassing the air heater through the circumference of the air heater, only air that bypasses the furnace altogether and short circuits to the flue gas flow. In reality, there is no simple or effective way to take an actual measurement of leakage around the circumference of the air heater. These leakage rates must be calculated using pressure differentials and measured gaps between the rotor and the circumferential/bypass seals - with allowance for structural deformation at operating temperature including rotor expansion and chord distortion between diaphragms. Circumferential/bypass leakage has an effect on heat transfer and boiler heat rate, but only a small effect on fan horsepower consumption because the total flow does not increase for increased leakage. Radial seal leakage is typically calculated as a percentage of the boiler exit gas flow, not a percentage of fan input air flow. Gas flow percentage is convenient when doing overall boiler efficiency tests, because it is useful for calculating the "correction" in gas exit temperature that results from air in-leakage. However, because boiler air in-leakage and/or air heater leakage doesn't account for the incoming unit airflow, the preheated combustion air being delivered from the air heater as well as the incoming flue gas (paths 1 & 2) are often overlooked when conducting a thorough performance evaluation. Furthermore, there are four distinct leakage paths through regenerative air heater seals (Paths A, B, C & D). Each leakage path affects the economic operation and heat rate of the plant in a different way. The leakage paths are illustrated in figure 1.

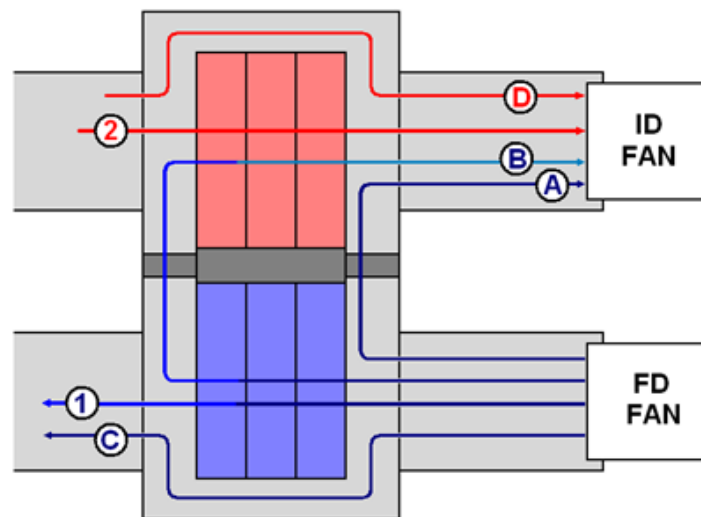

Figure 1 – Leakage paths through a regenerative air heater

PATH 1: Normal airflow path

PATH 2: Normal gas flow path

PATH A: Ambient FD fan flow leaking directly to the gas outlet duct (through the radial or circumferential seals)

POWER-GEN EUROPE 2010

Track 6, Session 4: Operations & Maintenance

- PATH B:** Pre-heated FD fan airflow that short circuits back to the gas outlet duct
- PATH C:** Ambient FD fan air that leaks around the air heater and enters the boiler unheated
- PATH D:** Hot gas exiting the boiler, going around the APH and exhausting at a high temperature

Sample Grid Considerations

In an effort to measure the flue gas entering and exiting an air heater, the testing grid should be reasonably spaced with enough points to represent at least 1 test point per 7-9 square feet of ductwork. However, more test points are not a substitute for an insufficient number of test ports.

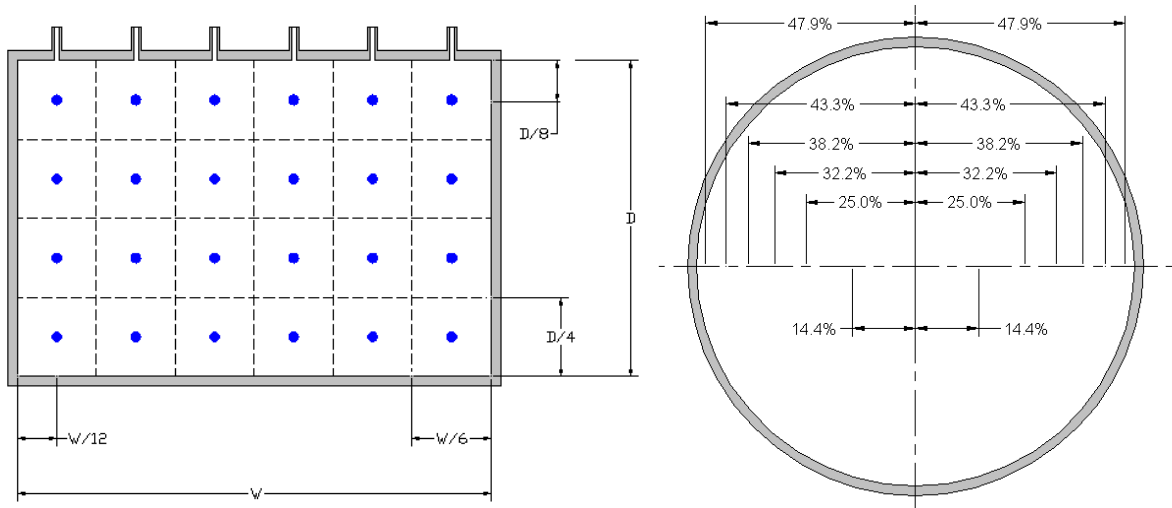

Figures 2 & 3 – Test port layout

If specific points within the duct are suspected of more than average leakage such as points near radial seals of an air heater or expansion joints, additional test points may be necessitated. However, these additional points should represent a smaller area than the rest of the test points if the spacing is non-uniform. The weighting for these points should be in accordance with the area they are representing.

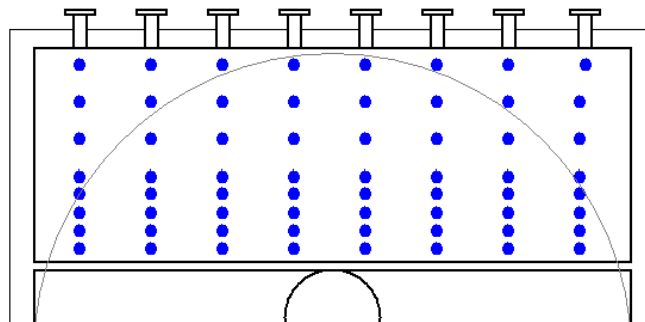

Figure 4 – Example of a non-uniform test grid near an air heater radial seal

Large stratifications in flue gas constituents are common. Therefore, velocity measurements should be taken when possible to weight each test point by the velocity at that location. If a non uniform test grid and velocity profiles are used simultaneously, then extra care needs to be taken so that each test point is properly weighted.

Measuring Air Heater Leakage

The typically large volumes of fan air leaking through the radial seals and into the exhaust gas stream represent wasted horsepower on both the ID and FD fans. This leakage is measured as a percentage of gas flow and is calculated by comparing O₂ measurements at the inlet and outlet of the gas side of the air heater. Since ambient air has a constant O₂ concentration of 20.9%, an increase in O₂ is a direct representation of the amount of flow that is leaking into the hot gas outlet of the air heater. Radial seal leakage from the hot end and the cold end are measured jointly since there is no adequate method for measuring them separately.

Since O₂ concentrations and velocities vary greatly throughout the gas inlet and outlet ducts, it is critical to measure velocity pressure and temperature as well as O₂ and use a weighted average for each location. Sample points must also be close to the duct wall in the area directly downstream of the sector plates since most of the radial seal leakage is constrained close to this duct area with both O₂ and velocities being more than twice the overall average in these areas. Failure to obtain velocity readings or samples at an adequate number of locations (in particular locations in proximity to the sector plates) will lead to a substantial under-calculation of leakage. In some cases, the errors have been by a factor of three or more.

Due to the fact that air heater leakage is rarely measured as precisely as required to obtain a correct weighted average of O₂ and velocity, air heater leakage is likely to be grossly underestimated if calculated using limited test points, stationary instrumentation, or by not weighting oxygen concentrations with velocity pressures. Within the U.S., air in-leakage is commonly calculated as follows:

$$\text{Leakage (\%)} = \frac{O_{2 \text{ Out}} - O_{2 \text{ In}}}{20.9 - O_{2 \text{ Out}}} \times 90$$

There are two penalties when referencing radial seal leakage. The first is the thermal losses associated with the leakage air cooling the air heater. The second is the additional auxiliary horsepower consumed by the fans for pushing more flow. The first step in determining the thermal loss is to determine the gas outlet temperature corrected for no leakage. The performance test code assumes that all of the air in-leakage occurs on the cold side. However, in reality it is a mix of the hot and cold side radial leakage. The hot side radial leakage does not cool the outlet temperature as much as the cold side leakage does. While the exact split will vary and is un-measurable, a good assumption is that the leakage is biased 60%/40% to the cold side due to higher differential pressures, the effects of cold end corrosion opening the seals, and the higher density of cooler air at the cold end of the air heater. Since the hot side radial seal leakage returns some of its heat to the cold air, use the gas outlet temperature instead of the air outlet temperature. An equation commonly used to calculate the corrected gas outlet temperature with provisions for hot side radial leakage is as follows:

$$T_{\text{Gas Out Corrected}} = \frac{\% \text{ Leakage} \times C_{p_{\text{Air}}} \times (T_{\text{Gas Out}} - (60\% \times T_{\text{Air In}} + 40\% \times T_{\text{Gas Out}}))}{C_{p_{\text{Gas}}}} + T_{\text{Gas Out}}$$

Once this is calculated, the total enthalpy drop for the gas and the enthalpy rise for the air should be calculated to determine the heat transfer efficiency. Dividing the enthalpy rise of the air by the enthalpy drop of the gas will give you the overall heat transfer efficiency for the air heater.

$$\text{Heat Transfer Efficiency} = \frac{C_{p_{\text{Air}}} \times (T_{\text{Air Out}} - T_{\text{Air In}}) \times \text{Air Mass Flow}}{C_{p_{\text{Gas}}} \times (T_{\text{Gas In}} - T_{\text{Gas Out Corrected}}) \times \text{Gas Mass Flow Less Leakage}}$$

The other impact radial leakage has on the bottom line is the increased flow through the fans caused by the increased airflow. The flow and static pressures at a fan can be used to find the fan efficiency on a fan curve as follows:

$$\text{Power Consumption} = \frac{\frac{\text{Flow (ACFM)} \times \text{Static Pressure ("w.c.)}}{6356}}{\text{Fan Efficiency} \times \text{Motor Efficiency}} \text{ Hp}$$

Calculating the motor horsepower and understanding the heat rate impacts of the air heater, system draft and unit load is extremely important when conducting a holistic evaluation of a system. For example, draft increases typically make just as much impact on fan power consumption as the flow increase. Total draft and flow impacts can be evaluated on a case by case basis provided the system leakage and static pressures have been measured along with design APH and fan data.

The ASME PTC 4.3 Air Heater Test Code differs slightly from how the testing is actually performed in that code specifies the comparison of carbon dioxide before and after the air heater instead of oxygen. Unfortunately, not ALL of the leakage paths can be measured using the ASME PTC 4.3 code and CO₂ is typically a calculated value, not measured. The code has no provision for air or gas bypassing the air heater through the circumference of the air heater; only air that bypasses the furnace altogether and short circuits to the flue gas flow.

Gases Leaking Past the Bypass/Circumferential Seals

A considerable amount of additional air heater leakage occurs around the perimeter of the air heater through the bypass/circumferential seals. Due to its physical location, this leakage is not measured nor included in the normal air heater leakage percentage number because the ASME test procedures have no method to either measure or include it. This is also why leakage is sometimes referred to as “*air in-leakage*” – because gas leakage cannot be measured.

The following 3-D diagram (Figure 5) is a good representation of the various leakage paths through the air heater. In this diagram, the leakage through the circumferential seals (also may be referred to as peripheral seals or bypass seals) is depicted at the bottom.

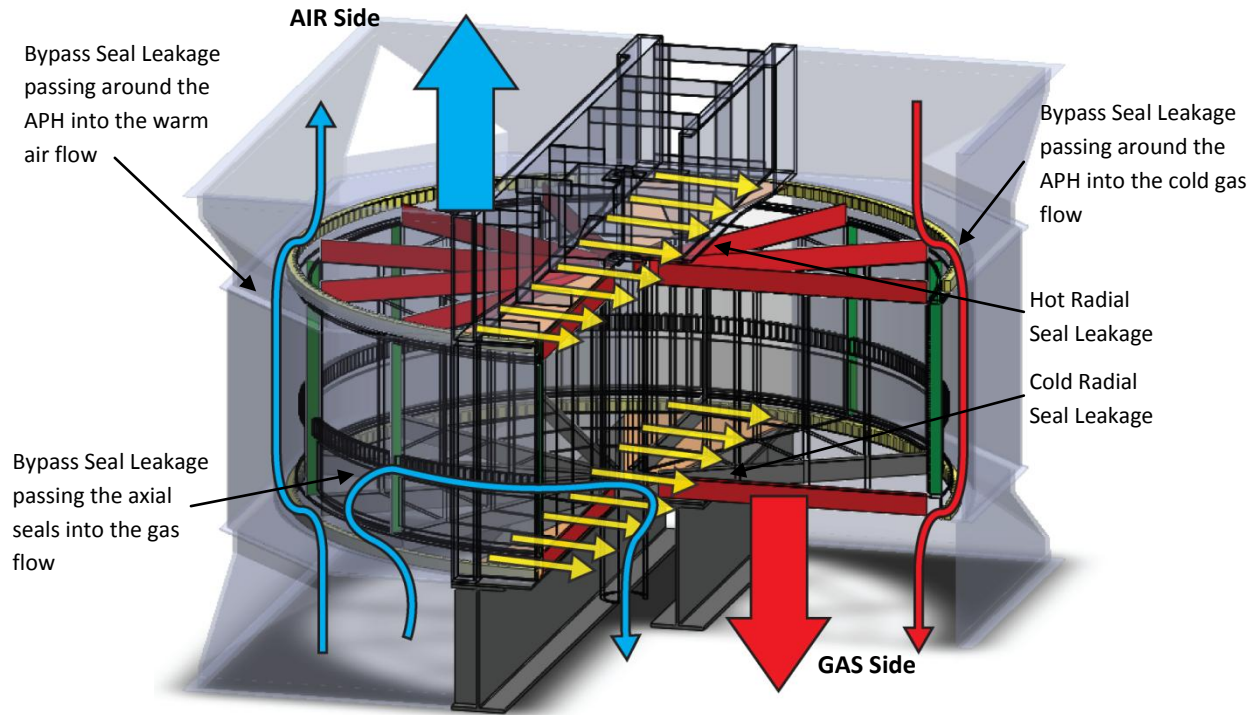

Figure 5 – Circumferential leakage through an air heater

Circumferential seals are located on the entire circumference of the air heater rotor, on both the hot end and cold end of the air heater. On the flue gas side of the air heater, all of the leakage through the inlet side circumferential seals will short circuit around the air heater (bypassing the heat transfer element) and exit through the downstream circumferential seals. This leakage results in a loss of enthalpy transfer into the element bundle, and increases the temperature (and therefore the actual volume) of gas entering the ID fans. On the air side of the air heater the volume of leakage through the first set of circumferential seals, will enter the annulus around the perimeter of the rotor, where the leakage will split in two directions. The volume in each direction depends on the differential pressures between points of exit. A portion of the flow will continue in a straight path and exit through the second set of circumferential seals. The remainder of the flow will be directed around the perimeter of the rotor and exit into the exhaust gas stream (through the axial seals) and that volume will, in turn, exit the air heater through the gas side-cold end circumferential seals.

Distortion takes place in the rotor after it heats up in normal operation. This distortion, known as turndown, opens gaps between both the radial and circumferential seals and their respective sealing surfaces. This phenomenon must be accounted for when setting the seals at a cold state.

There have been many questions raised about the quantification of leakage flow rates through the perimeter seals. Unlike leakage through radial seals, which can be calculated by a variety of established methods such as The American Society of Mechanical Engineers (ASME) PTC 4.3 test code for air heaters, there is no established method for testing or measuring leakage through the perimeter seals in an air heater. One possible approach to calculating perimeter leakage is to use a Computational Fluid Dynamics (CFD) model that takes into account the geometry of the

air heater as well as the differential pressures between the various entry and exit points of the leakage.

For simplicity, the following method can be used to approximate the leakage rates. While it is understood that this is just an estimate, it does give a general idea of the impact of bypass seal leakage. This equation is designed to calculate flows through large openings of defined shape, of the “flat plate orifice” type such as windows and vents. While not a perfect match to perimeter leakage in an air heater, it provides a closer approximation than traditional Crack Flow Equations for ventilation systems which are more appropriate for very small openings with very small differential pressures. (Figure 6)

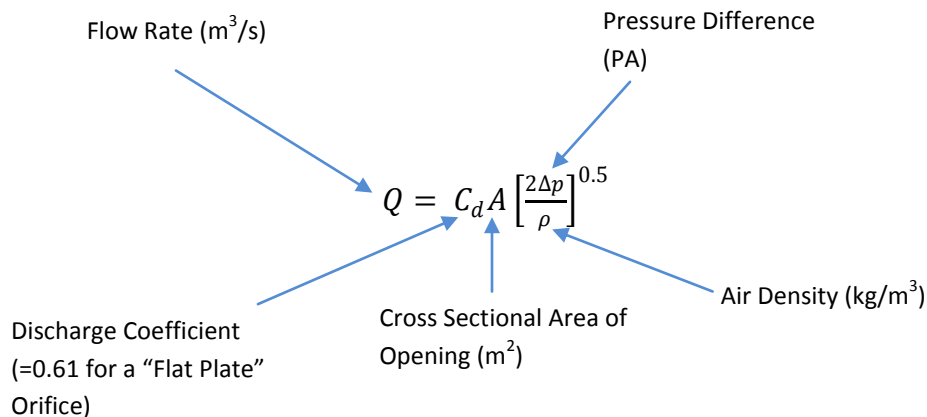

$$Q = C_d A \left[\frac{2\Delta p}{\rho} \right]^{0.5}$$

Flow Rate (m³/s) → Q

Pressure Difference (PA) → Δp

Discharge Coefficient (=0.61 for a “Flat Plate” Orifice) → C_d

Cross Sectional Area of Opening (m²) → A

Air Density (kg/m³) → ρ

Figure 6

The flue gas passing through the bypass seals contains heat energy that completely bypasses the air heater and is never captured. This contributes to a loss of thermal efficiency (enthalpy loss) and thus requires increased unit fuel consumption. The open area can be calculated using the gap between the circumferential seals and the mating surface. The equation is then repeated using the recommended tolerances for the circumferential seal gaps. (The design or target air heater differential should also be used because bypass leakage will decrease with a lower differential pressure). Using the air heater heat transfer efficiency, the heat potential of the gas can be calculated.

The calculable savings for improving air heater leakage is substantial. In addition there are significant costs related to the impact non-optimum airheater performance has on the combustion process, FD and ID fans, as well as erosion concerns downstream, precipitator performance issues due to higher inlet velocities (offset slightly due to decreased flue gas temperature) and possible cost impacts of colder combustion air. In order to properly assess air heater performance, the temperatures in and out of both sides of the air heater need to be known as well as the oxygen concentrations before and after the gas side of the air heater. Velocity heads need to be measured as feasible to determine if there are any significant flow stratifications in the ducts. If so, the temperature and oxygen should be averaged on a flow weighted basis. Furthermore, to perform a proper thermal heat balance, the air and gas flows need to be known as well before and after the air heater.

This can be calculated as a function of static pressure, temperature and velocity head measured at each of the testing locations (Figure 7).

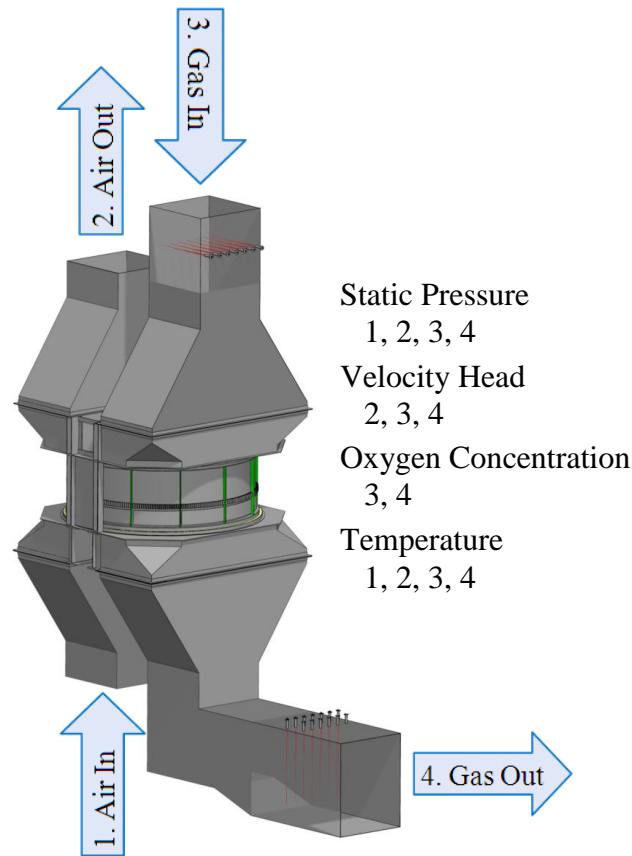

Figure 7

In conjunction with fuel changes or the modernization and refurbishment of aging units, a thorough performance evaluation is crucial. This is especially true when taking into account reliability, performance and overall unit performance improvements with the implementation of high performance air heater components. Part of the author's experience is that all paths of airflow at various points on a large utility boiler should be periodically measured to validate the design and theoretical flow rates against "actual" measured values. One example of some previously published data by Storm Technologies in 2008 to validate the importance of measured input airflow for stoichiometric firing system control is shown as figure 8.

Furthermore, another paper presented by Storm Technologies, Inc. in 2010 validates a process of monitoring system air in-leakage online by utilizing and comparing "real-time" calculated theoretical values against proven and calibrated airflow measuring elements and representative flue gas oxygen readings from the boiler exit.

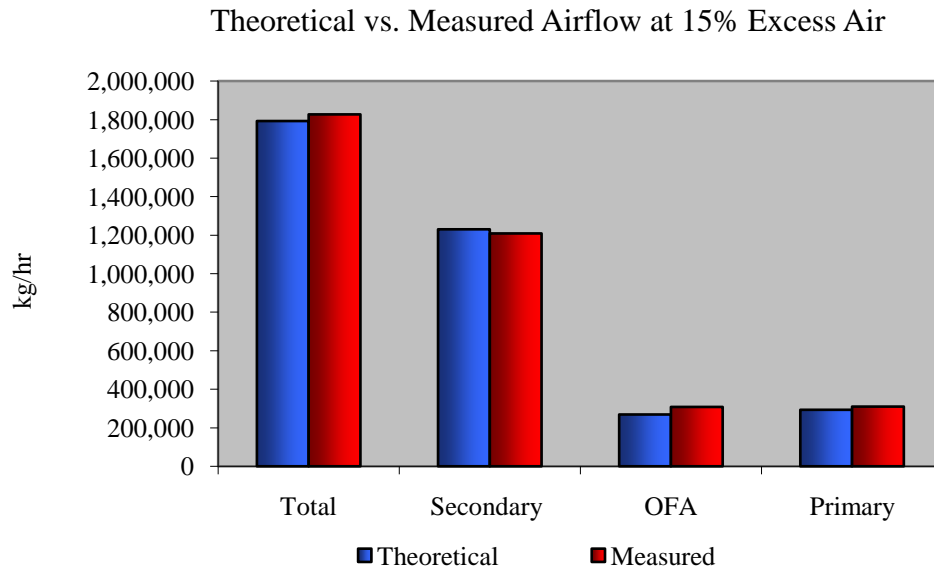

Figure 8, Theoretical vs. Measured Airflow on a 460MW unit

Considering the previous, a thorough performance evaluation of the air & flue gas systems of a large utility steam generator is often required for optimization and economic justification of improvements to be completed at the air heater, as discussed in the following section.

Direct Effects of the Air Heater on Fuel Consumption and CO₂ Emissions

Because the rotary regenerative air heater on a coal fired power boiler is directly responsible for at least 10 % of the thermal efficiency of the unit, it is critical that existing air heaters be physically optimized to meet the current challenges for increased fuel efficiency and reduced air pollution emissions. In many units, excessive air heater leakage can deteriorate the overall net unit efficiency by ½% to 2%. Research and modeling performed by Teodor Skiepkowski and Ramesh K. Shah - in articles published in 1999 and 2004 - concluded that just 10% leakage can reduce the overall thermal efficiency of an air heater by 9.8% to 13.2% - depending on the proportion through each leakage path. This is a very substantial decrease in performance.

In considering the fact that some air heaters have measured leakage rates in excess of 30%, the impact of air heater leakage on a unit's performance and efficiency is something that must not be ignored, especially when additional consideration is given to the fact that a poorly operating air heater can affect the coal grinding and combustion process to the extent of causing an additional 1% to 5% or greater overall net efficiency penalty on the unit. Additionally, in recent years, there has been great emphasis placed on the need to reduce CO₂ emissions from coal fired power plants. For every extra ton of coal that is consumed due to a loss in unit efficiency resulting from air heater leakage, there will be approximately an additional 2.4 tons of carbon dioxide emissions from the power plant. In some instances, poorly operating air heaters may cause several hundred thousand extra tons of CO₂ to be emitted each year from a typical 500 MW power plant. Depending on the type of coal being burned, on a typical 500 MW unit, a 1% efficiency gain achieved by addressing air heater leakage issues can result in an overall reduction in fuel

consumption of 35,000 tons/yr and reduced CO₂ emissions in the range of 100,000 tons per year. It is easy to conclude therefore, that there is a very real need to address and rectify the air heater leakage issues that exist in almost all existing air heaters.

Air Heater Leakage

The main advantage of the regenerative air heater is that it is probably the least expensive heat recovery device that is able to operate reasonably well in the harsh environment of the flue gas exhaust stream from a fossil fired boiler. A major drawback of the regenerative air heater is the undesired leakages that are inherent to the design of the device. Regenerative air heaters capture the heat in boiler exhaust gases by passing them over heat-adsorbing metallic elements. In the most common design of regenerative air heater (Ljungström™) the elements are continually rotated so that they alternately contact the hot gases and cool the inlet air produced by the plant's forced-draft fans. The captured heat is released into the cooler inlet air stream and recycled back into the boiler. Typically, about 50% to 60% of the total heat content of the exit gasses are captured and recycled, resulting in the aforementioned improvement in boiler efficiency of about 10% when compared to an identical unit without an air heater.

It's extremely difficult to seal these types of heaters because their large diameter (up to 60 feet across) and the large temperature difference between their hot and cold ends (about 400 degrees F). These work together produce significant radial thermal expansion difference between the hot and cold sides of the air heater's rotor after unit start up. Due to this inherent thermal distortion, it's not uncommon for the outer edges of a large air heater at operating temperature to "droop" (or "turn down") by 3 inches or more, compared with the cold condition (Figure 9).

Blue = Cold Condition of Rotor

Yellow = Hot Condition of Rotor

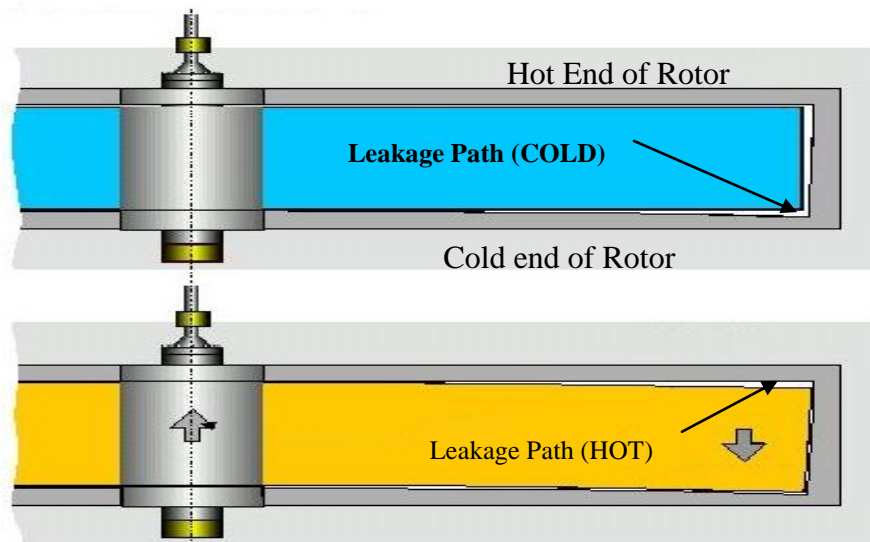

Figure 9, Thermal Turn-down

The distortion caused by this thermal turndown opens gaps in the sealing surfaces that separate the cold incoming gasses as well as in the sealing surfaces around the circumference of the air heater. The flow paths associated with these gaps were shown previously in Figure 9.

Radial seal leakage is expressed as a percentage and basically represents the % increase in outlet gas flow caused by the mass of inlet air leaking through the radial seals into the gas outlet stream. Shockingly, radial leakage rates over 40% have been measured in some air heaters, and leakage rates around 20% are often accepted as a “normal” condition. However, leakage at this level places a significant extra burden on the boiler fans in order to move gas and air that serves no useful purpose. The burden placed on the fans is often exacerbated by the fact that, in many plants changes in fuels and operating conditions over the years have resulted in induced draft fans operating at near capacity. As shown in Figure 10 when a fan is operating at over 80% of capacity, the slope of the horsepower/volume curve becomes very steep. At near full capacity, a 1% increase in fan volume can actually result in a 3% increase in required fan horsepower. In these cases, even a small reduction in radial seal leakage can yield very large benefits considering that fan motors are one of the largest electricity users in the entire plant.

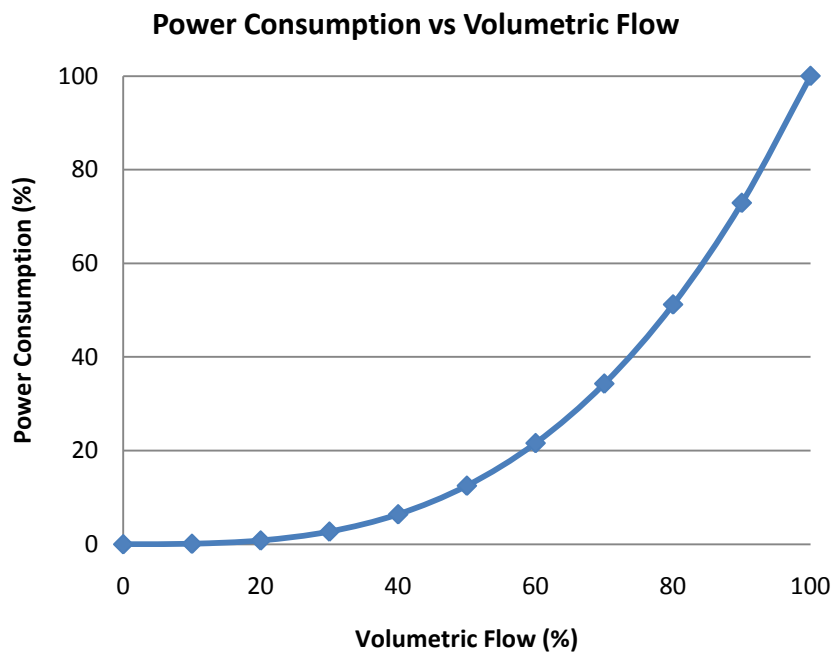

Figure 10, Flow Volume vs. Power Consumption (*Speed Control Theoretical*)

In some plants, the fan horsepower wasted in handling radial seal leakage can exceed 3MW which can result in an overall net heat rate penalty in the range of 50-75 BTU/KWH – a ½ to ¾ % decrease in overall unit efficiency. On a typical 500 MW unit, this magnitude of radial seal leakage can result in excess coal consumption in the range of 15,000 – 20,000 tons/yr with resulting carbon dioxide emissions in the range of 35,000 – 50,000 tons/yr compared to a more tightly sealed air heater. This same thermal turndown is also the primary cause of circumferential leakage around the perimeter of the air heater. This perimeter leakage can sometimes result in a thermal penalty that is even greater than that caused by radial seal leakage as air and gas bypasses the air heater without the net benefits of enthalpy transfer. As previously noted, standard air heater leakage tests cannot detect the quantity of air and gas that leak around the perimeter of the rotor, and traditionally this type of leakage has been discounted as being insignificant. However, the perimeter leakage can be calculated with some degree of accuracy

using orifice calculations, and the effect of this leakage on the air heater efficiency can be estimated by the methods published by Skiepko and Shah. Based on their calculation methods it is feasible that circumferential leakage can result in air heater efficiency penalties that can affect the units net heat rate to a degree equal to, or greater than, that of radial seal leakage (an additional 50-75 Btu/Kwh or ½ to ¾% in overall unit efficiency compared to a non-leaking air heater).

Leakage Solutions

A cost effective and simple method for reducing air heater leakage is replacement of the original equipment type air heater seals with newer design high performance full contact radial seals and self reinforcing circumferential/bypass seals such as those shown here (supplied by Paragon Air Heater Technologies). Full contact seals have a proven track record of reducing air heater leakage by approximately 50% compared with the original equipment type radial seals Figure 11 seals commonly found today on most air heaters. An example of a high performance full contact radial seal (DURAMAX™) is shown in Figure 12. In comparison with an original design seal, which is really a rigid “proximity” air dam, the full contact seal is constructed with a spring bellows that allows the seal to maintain a continuous, but flexible contact with the sealing plate at all times, effectively eliminating the main path for radial seal leakage. The high performance circumferential seals (DURAFLEX™) shown in Figure 13 have an interlocking/self reinforcing structural design which allows the seals to be set in close proximity to the rotor sealing surface without being damaged, thus minimizing the gaps and leakage openings in comparison to original style seals (Figure 14). The following photographs illustrate the differences in these seals.



Figure 11, Original Style Radial Seal Design

DuraMax™ Radial Seal



Figure 12, Continuous Contact DURAMAX Seal (before & after sector plate contact)



Figure 13, DURAFLEX Circumferential Seal



Figure 14, Original Style Circumferential Seal

Leakage Reduction Case History

The following case history illustrates the positive benefit of leakage reduction accomplished with full contact radial seals. A reduction in induced draft fan amperage of over 23% was achieved with full contact DuraMax seals at the AEP Welch Station, a 500MW coal fired plant in Texas, USA.

Test results from AEP Welch:

FAN	Before (AMPS)	After (AMPS)
3A ID FAN	572	459
3B ID FAN	691	468
3A FD FAN	131	125
3B FD FAN	128	113

Table 1, 23% Reduction in total fan amps with full contact radial seals

Erosion Issues

Erosion of air heater hot end element, bypass seals, and air heater diaphragms have been reported at many power plants. Concern has been noted regarding the rapid loss of heat transfer element as well as damage to perimeter seals and rotor diaphragms. The high ash content associated with many of the coals used in these plants is obviously a contributing factor. However, two other factors with regard to erosion are actually more important than ash content.

These are:

1. Ash abrasiveness
2. Ash velocity

Abrasiveness

The abrasiveness of fly ash increases as the amount of glass forming minerals increases. The primary glass forming minerals are Silica and Alumina. In the case of some low rank coals, the Silica and Alumina content of the ash can amount to about 90% of the total mineral content by weight. This composition makes this ash much more abrasive than ash from most other coals around the world.

Ash Velocity

Velocity is much more important than ash content or abrasiveness when it comes to determining the rate of erosion. The basic erosion equation illustrates that the velocity of the ash is a factor of three higher than the ash content when determining the erosion rate.

The basic erosion equation is: *Erosion Equation* = $CxMxV^n$

Where:

- E- Erosion Rate (L/T)
- C-Correlation Const.
- M-Mass Flux (M/T-L²)
- V-Gas Velocity (L/T)
- n-exponent (2.5-3.5)

The above equation is useful in illustrating that ash quantity alone is not the primary cause of erosion in the air heater- and that ash velocity is much more critical. The average velocity of the gas stream entering an air heater is typically around 15 m/s. Velocities of this magnitude will not automatically result in rapid erosion even if the gas stream has a high concentration of ash. However, the overriding issues that are the most likely causes of erosion are:

1. Ash abrasiveness
2. Turbulence

Abrasiveness

Although it may not be practical to reduce abrasiveness by changing the coal source and its associated ash chemistry, it may be possible to reduce abrasiveness by reducing the size and weight of the ash particles themselves. This result can be achieved by increasing the fineness of the coal particles leaving the pulverizers, and also balancing the coal and air flows to each of the burners. Currently in the United States, many combustion experts are recommending a coal fineness of 75% through a 200 mesh screen. Such a fineness level will not only reduce the mass of each ash particle, but will also result in more efficient and uniform combustion in the furnace. In addition to the potential reduction in ash abrasiveness, an improvement in fineness and coal particle distribution can, as previously discussed, result in a dramatic improvement in boiler operation and efficiency.

Turbulence

The turbulence of the gases and ash entering the air heater must also be carefully considered when addressing the erosion issue. The rate of erosion is also a function of the *angle of impact* of the ash on the affected surface. Excess turbulence will result in angular impact of ash particles which will greatly increase the rates of erosion. Turbulence in the gas/ash stream and non-uniform flows entering the air heater cannot be completely eliminated, but can be mitigated to some extent with the installation of flow strengtheners and turning vanes upstream from the air heater. It is highly recommended that flow model studies be performed prior to a full scale installation in order to increase the probability of a successful project. Non-uniform flows can also result in high velocity slipstreams and erosion of the type illustrated in Figure 15 which shows severe erosion in the outer basket rings. While uniform flow distribution may eliminate this problem, the issue can also be addressed by altering the element profiles and metal thicknesses. One approach is to install an additional thin (8" to 12") layer of cold end style element (commonly referred to as NF-6 profile) on the HOT end of the air heater. This element

can be manufactured in heavy gage steel (.050” – 18 gage) as opposed to the lighter gage material of the hot end element (0.24” – 24 gage) as shown in Figure 16. This layer of non-turbulent element of heavy gage steel slow the rate of erosion in the hot end element by straightening the gas flow and eliminating the angular impact of the abrasive ash on the hot end element. In effect, the NF-6 layer will become a longer life sacrificial layer which would not only be easy and inexpensive to replace. Since this is an “additional” layer, any erosion in this layer that may occur over time would not degrade the design thermal efficiency of the air heater. It should be noted that the more complex profiles of typical hot end element (such as DU “double undulated” profile) cannot be effectively manufactured in the thicker 18 gage material due to the complexity of the interior channels that promote heat transfer.



FIGURE 15, Outer ring basket erosion

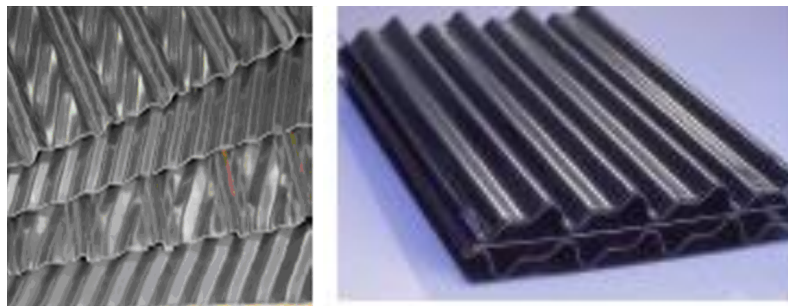

Figure 16, Heavy gage NF-6 element (right) and Lighter gage typical hot end element

Reducing Air Heater Outlet Gas Temperature

The correct performance of an air heater is so critical to unit efficiency that just a 10°F change in gas exit temperature will change the boiler efficiency by 1/4%. In order to minimize both fuel consumption as well as the emissions of CO₂, it is recommended that air heaters be operated at as low an exit gas temperature as can be tolerated without excessive acid condensation on the cold end element. With that in mind it should be remembered that the cold end element layer in an air heater is intended to be a *sacrificial* layer that is intended to bear the brunt of the effects of acid condensation and is designed to be replaced relatively easily at modest cost.

Compared to the cost of the excess fuel that must typically be burned to maintain a gas outlet temperature well above the dew point to reduce cold end corrosion, the cost of a replacement set of cold end baskets is almost incidental. In modern power plant operation, it should be the goal of every power plant to achieve minimum gas outlet temperatures by maximizing air heater heat transfer efficiency. A complete discourse on methods to reduce gas outlet temperature cannot be included in a paper of this size; however, here is an overview of two approaches that can be used to change gas outlet temperature without the necessity of changing element profile type.

Increased Element Depth

Most of the air heaters installed today were originally designed with some open space that can accommodate several inches to several feet of additional heat transfer element. Additional element depth is most easily added during routine basket replacements. The air heater basket supplier should supply the calculated temperature changes that will be achieved with the change in element depth. Also available is a basket design most often referred to as a “*low profile*” basket. This basket design has the same outside depth as a standard basket, but will accommodate up to 3 inches of additional element depth than a standard basket because the design eliminates the need for deep structural bars at the top and bottom of the basket. This design is especially useful for increasing heat transfer in air heaters that do not have any available space for element depth expansion.

Air Heater Speed of Rotation

The rate of heat transfer in an air heater is affected somewhat by the speed of rotation of the rotor. Small changes in rotational speed can be made with the simple addition of an inexpensive variable speed drive on the motor of the air heater drive. By making small changes in the speed of rotation, and monitoring each change over a period of several days, it may be possible to achieve a significant reduction in air heater gas outlet temperature at very little cost and with virtually no downtime. This concept, although new, has shown promising results in full scale tests at a unit in North Carolina, USA. Due to the large amount of metal mass in each air heater and the large amount of thermal inertia, it has been observed that it may take several days before the results of a small change in air heater speed change will be detectable.

Conclusions

From the standpoint of the thermal efficiency of a power plant, the air heater is a critical piece of equipment. Even a small deterioration in air heater performance can result in efficiency losses resulting in 50,000 tons/yr or more of wasted coal, and well over 100,000 tons/yr in unnecessary CO₂ emissions, not to mention the potential of load limitations due to fan losses associated with air heater leakage. Money spent on improvements made to air heaters can often have payback periods measured in weeks or months, not years as is typical with most power plant improvements. The magnitude of the potential economic and environmental gains that can be achieved with small improvements to existing air heaters indicates a strong need for the development of in-house engineering expertise to address air heater issues and implement improvements on an expedited basis.

Acknowledgements

The authors would like to thank Stephen Hall of Storm Technologies, Inc. for his support with this technical paper and also to Paragon Air heater Technologies for agreeing to share their expertise and technology in the field of regenerative air heater performance optimization.

References

- [1] ***“Real Time furnace Air In-Leakage Monitoring on Coal, Oil and/or Gas Fired Boilers”*** Stephen Hall (Storm Technologies, Inc), Stephen Storm (Storm Technologies, Inc.); Jack Lyons (OUC); Electric Power 2010
- [2] ***“The Extreme Importance of Total Air & Fuel Flow Measurement on a 450MW B&W Wall Fired Unit firing high sulfur fuels”*** Stephen Storm (Storm Technologies, Inc.); Jack Lyons (Orlando Utilities); PWR2008-68024, Electric Power 2008
- [3] ***“A Review of the Importance of Measuring and Controlling the Furnace Inputs on a Typical PC Fired 500MW boiler”*** R.F. Storm, Stephen Storm, POWER MAGAZINE, October 2007
- [4] ***“Influence Of Leakage Distribution On The Thermal Performance Of A Rotary Regenerator”*** R.K Shah, T. Skiepko; Applied Thermal Engineering 19 (1999) 685-705
- [5] ***“Modeling And Effect Of Leakages On Heat Transfer Performance Of Fixed Matrix Regenerators”*** Teodor Skiepko, Ramesh K. Shah; International Journal of Heat and Mass Transfer 48 (2005) 1608-1632.
- [6] ***“Air Heater Leakage: Worse Than You Think”*** John T. Guffre (Paragon Airheater Technologies); POWER MAGAZINE, April, 2006.
- [7] ***“Reducing Preheater Leakage Boosts Output and Availability”*** John T. Guffre, (Paragon Airheater Technologies); POWER ENGINEERING, August, 2005.
- [8] ***“An Update on Performance Optimization and Efficiency Improvement Programs completed at State Electricity Board Operated Coal Fired Power Plants in India through the Asia Pacific Partnership on Clean Development and Climate (APP)”*** POWER-GEN Asia, Bangkok, Thailand 7-9 October 2009